

**PERSPECTIVE VIEW**

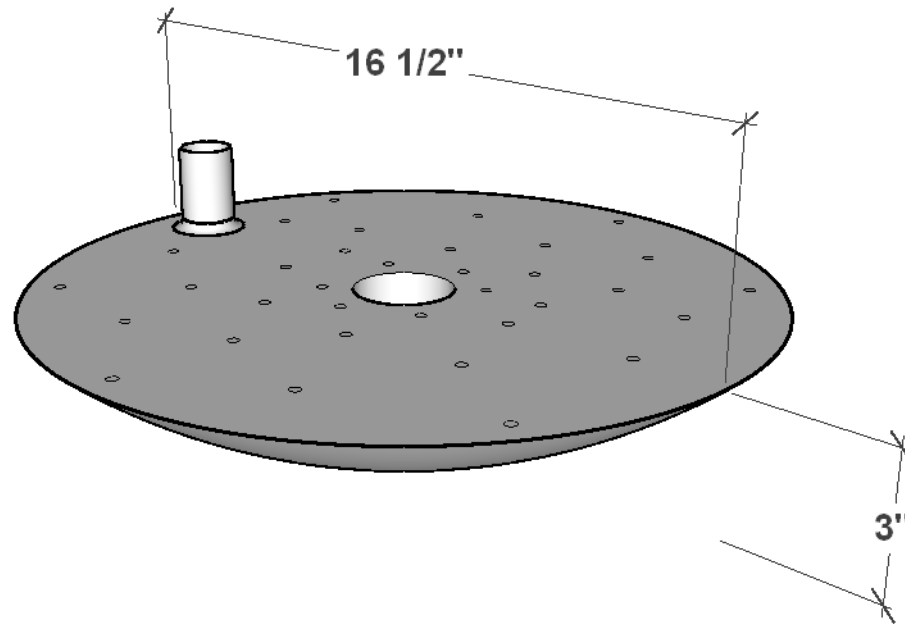

**PLANTERS**  
**UNLIMITED**  
 A CARLSBAD MANUFACTURING COMPANY

1 (888) 320-0626 | [PlantersUnlimited.com](http://PlantersUnlimited.com)

| GENERAL NOTES   |  |
|---|--|
| STANDARD DRAINAGE: YES <input type="checkbox"/> NO <input type="checkbox"/> |  |

| PRODUCT DESCRIPTION                  |          |                |     | SKU          |            |     |         | PREPARED FOR             |  | APPROVAL SIGNATURE |
|--------------------------------------|----------|----------------|-----|--------------|------------|-----|---------|--------------------------|--|--------------------|
| "Bow" Hanging Basket Water Reservoir |          |                |     | WW-100-HB-22 |            |     |         | -                        |  |                    |
| DIMENSIONS                           | MATERIAL | COLOR / FINISH | REP | DB           | DATE       | REV | ORDER # | PROJECT / SIDEMARK / IF# |  | APPROVAL DATE      |
| 22"dia.                              | -        | N/A            | N/A | IG           | 09/20/2024 | 1   | N/A     |                          |  |                    |