

Circumference is measured around the edge of the post

If your post is a different shape than shown on this drawing, please note the shape and diameter her:

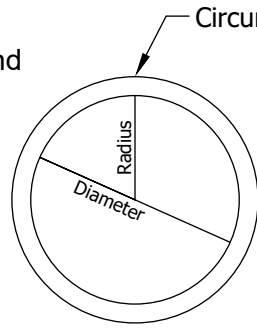

CHECK POST SHAPE

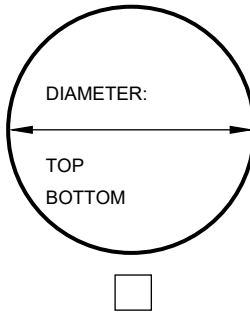

TAPERED POST? YES / NO (Please Circle)

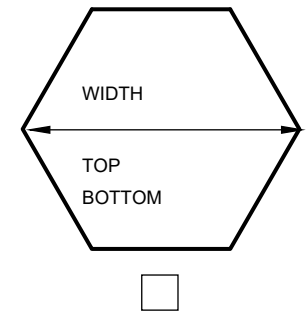
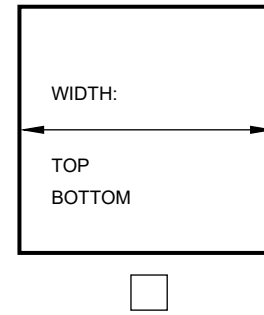

Bracket Clamps may differ in shape than your post. They are designed to use tension to stay in place

PLEASE MEASURE AT THE HEIGHT/LOCATION THE BRACKET WILL BE MOUNTED ON POST

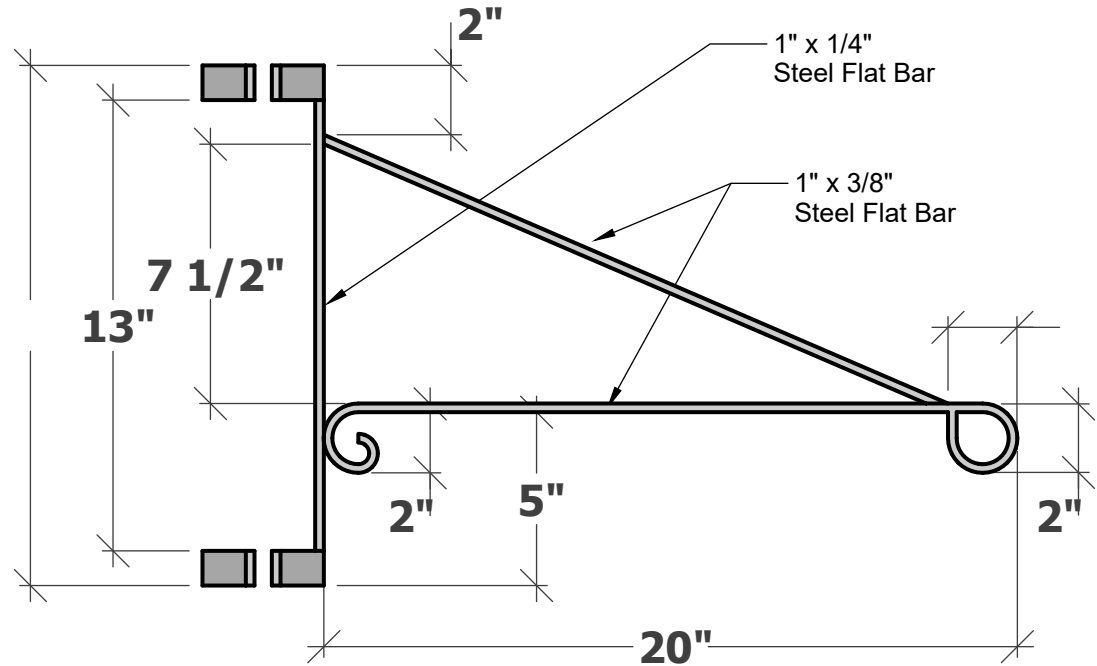

GENERAL NOTES	

PLANTERS
UNLIMITED

A Carlsbad Manufacturing Company

1 (888) 320-0626

www.plantersunlimited.com

PRODUCT DESCRIPTION				SKU				PREPARED FOR		APPROVAL SIGNATURE
ONE-WAY SCROLL ARM LAMP POST BRACKET				301-20				-		
DIMENSIONS	MATERIAL	COLOR / FINISH	REP	DB	DATE	REV	ORDER #	PROJECT / SIDEMARK / IF#		APPROVAL DATE
-	-	-	-	IG	02/11/2025	1	-			

PLEASE NOTE: Due to the handmade nature of our products, individual measurements may vary from those listed. The provided dimensions are for reference only. All images are the intellectual property of Planters Unlimited. Reproduction in any form is strictly prohibitive without the express written permission of Planters Unlimited. All designs are property of Planters Unlimited.