

**General Notes:**

- 1. Do you want our Standard Drainage Holes? (1/2" dia. holes) Yes: \_\_\_ No: \_\_\_
- 2. If no drain holes are requested it is assumed proper drainage will be added in the field.

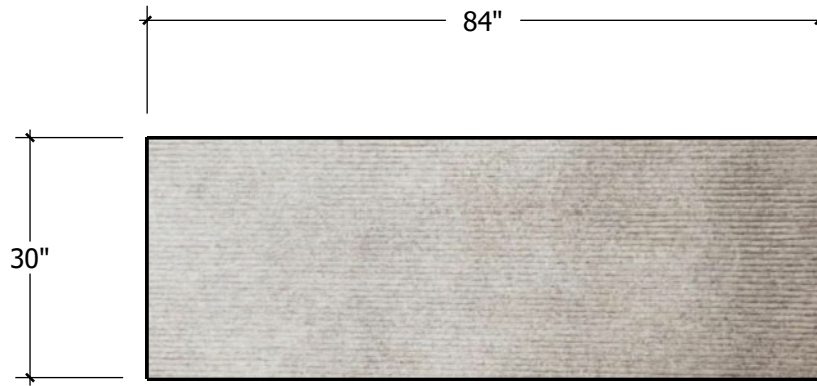

**FRONT VIEW**

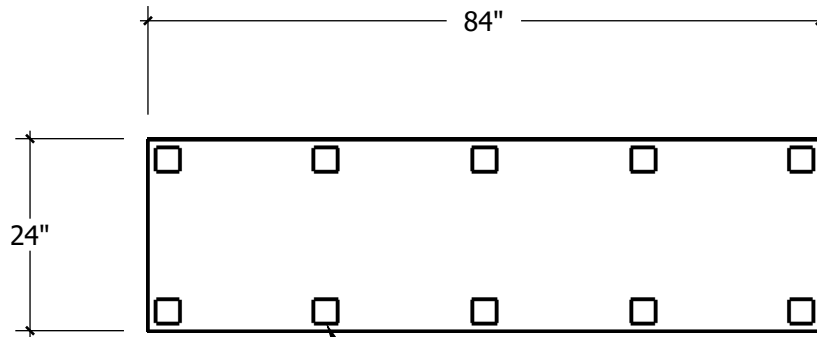

**BOTTOM VIEW**

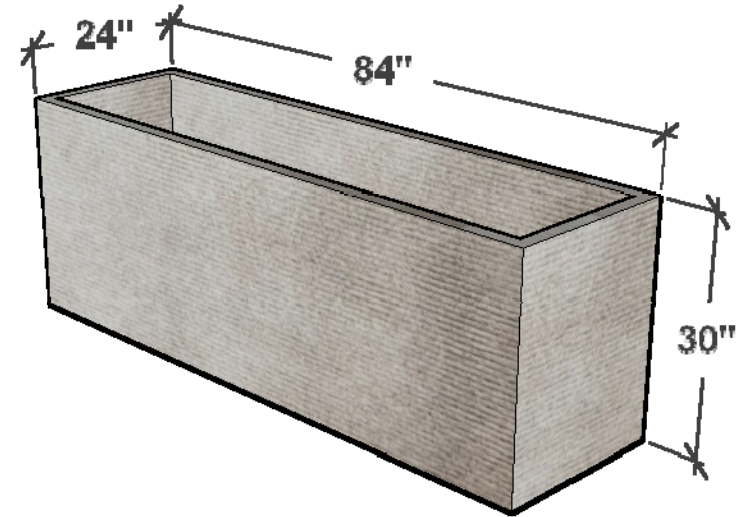

**PERSPECTIVE VIEW**

Date: 03/2021  
Scale: NTS  
DB: IG  
Rep:  
Order#:

Content: Verso Fiberstone Planter - 84" x 24" x 30"h  
PN: C19-VER-REC842430-FS  
Color/Finish:  
Customer Approval: \_\_\_\_\_

Design by Planters Unlimited  
All visual representations and designs are the intellectual property of Planters Unlimited and are protected under Copyright law. Any duplication of this design is in direct violation of the law and will result in legal action.

© Copyright 2008-2019

